





-  Design for 2.5GBase-T application
-  Compliant with IEEE802.3 standard
-  4-Pair PoE application with 720mA balanced DC line current capability
-  RoHS compliant



**ELECTRICAL SPECIFICATION @ 25°C**

Part Number	Ports	Operating Temp. Range	OCL @100KHz, 0.1Vrms	Insertion Loss (dB Max)			Return Loss (dB Min)	
				1-125MHz	1-40MHz	40-200MHz	1-40MHz	40-200MHz
824-00540F	1	0°C to +70°C	150uH min. with 15mA DC Bias	1.0	20		20-15Log(F/40)	
824-00541F	2	0°C to +70°C	150uH min. with 15mA DC Bias	1.0	20		20-15Log(F/40)	
824-00542F	1	-40°C to +85°C	150uH min. with 10.8mA DC Bias	1.0	20		20-15Log(F/40)	
824-00543F	2	-40°C to +85°C	150uH min. with 10.8mA DC Bias	1.0	20		20-15Log(F/40)	

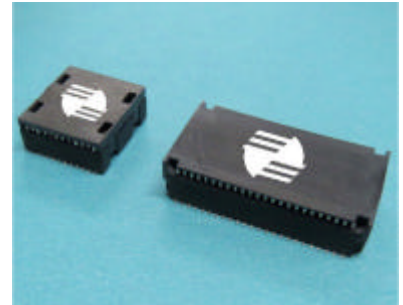
**ELECTRICAL SPECIFICATION @ 25°C**

Part Number	CMRR (dB Min)	CM-DMRR (dB Min)				Crosstalk (dB Min)	Hipot (Vrms)
		1-125MHz	1-10MHz	10-20MHz	20-125MHz		
824-00540F	30	48	48-20Log(F/10)	42-15Log(F/20)	30	1500	
824-00541F	30	48	48-20Log(F/10)	42-15Log(F/20)	30	1500	
824-00542F	30	48	48-20Log(F/10)	42-15Log(F/20)	30	1500	
824-00543F	30	48	48-20Log(F/10)	42-15Log(F/20)	30	1500	

**Notes:**

- "F" represents the test frequency specified in MHz.

**MECHANICAL DIMENSIONS**

824-00540F / 824-00542F

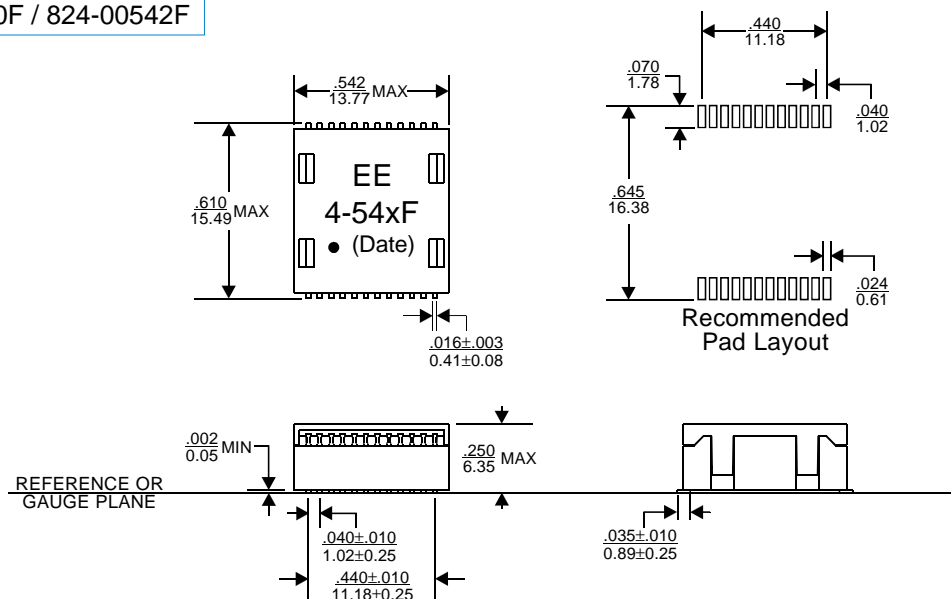

**MECHANICAL DIMENSIONS**

824-00541F / 824-00543F

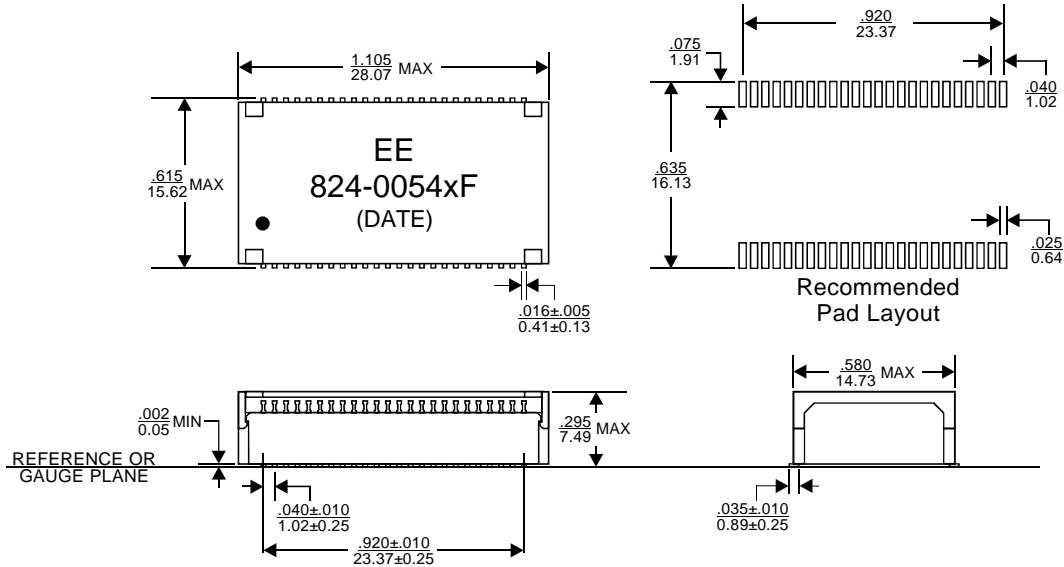

**Notes:**

- Dimensions are specified in inches with higher precedence in inches.  
mm
- Unless otherwise specified, all tolerance are ±  $\frac{.010}{0.25}$ .
- Coplanarity:  $\frac{.004}{0.10}$  max.
- "(DATE)" includes at least the manufacturing date code (in YYWW format).
- When ordering, please add suffix "T" to the part number for tape & reel packaging (330mm reel).

**SCHEMATICS**

824-00540F / 824-00542F

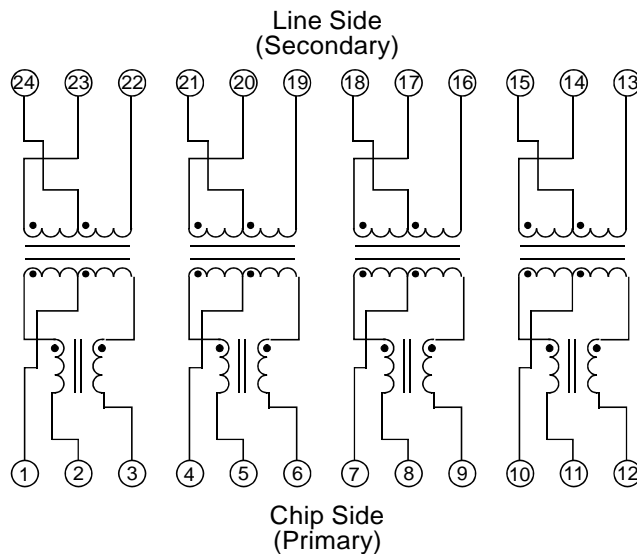

**SCHEMATICS**

824-00541F / 824-00543F

Line Side  
(Secondary)

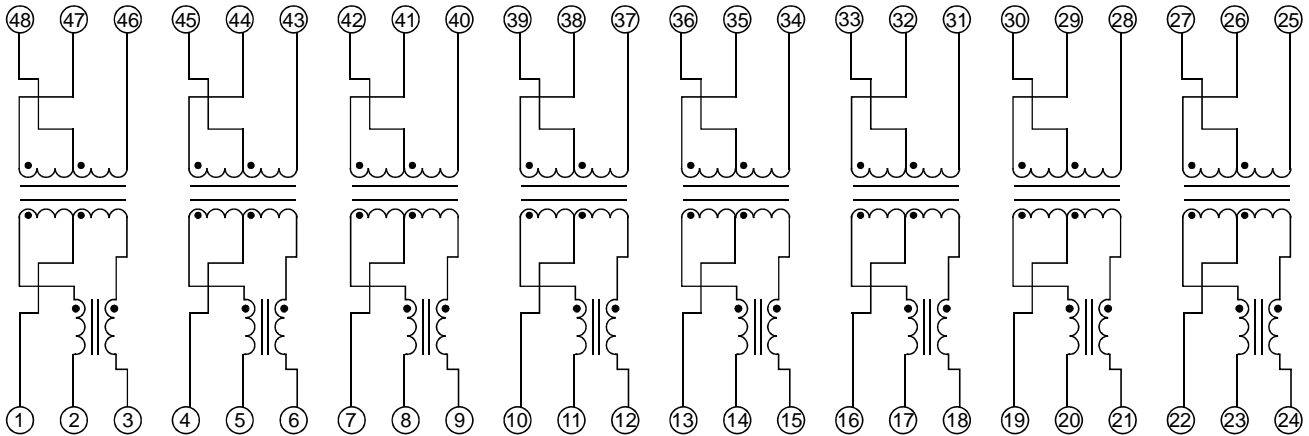

Chip Side  
(Primary)

**PACKAGING**

824-00540F / 824-00542F

USER DIRECTION OF UNREELING →

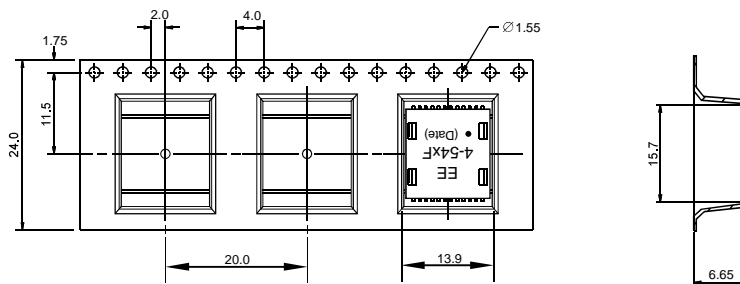

Weight (in gram) : 1.8 typ.  
Tape & Reel : 450 / reel

**PACKAGING**

824-00541F / 824-00543F

USER DIRECTION OF UNREELING →

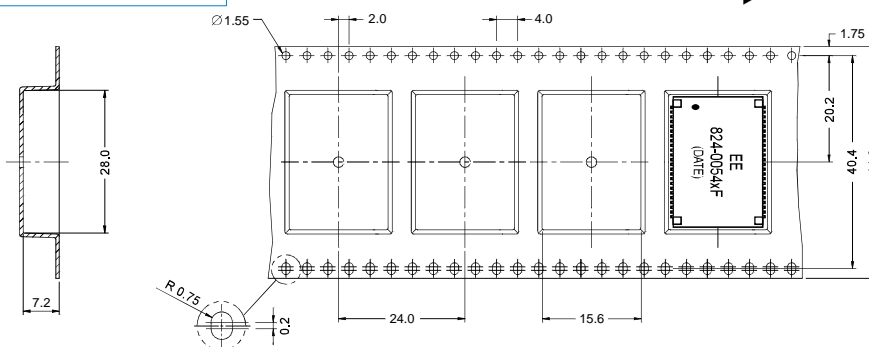

Weight (in gram) : 4.0 typ.  
Tape & Reel : 300 / reel

**FOR MORE INFORMATION, PLEASE CONTACT**

**HONG KONG**  
Flat G, 5/F, Valiant Industrial Centre,  
2-12 Au Pui Wan Street, Fotan, Shatin, N.T.  
Hong Kong  
Tel: (852) 2954 3027 Fax: (852) 2954 3304  
Email: eempl@eleceltek.com  
Website: <http://www.eemagnetic.com>

**PRC**  
No. 388 Lian Yun Road,  
Guangzhou Economic & Technological Development District,  
Guangzhou, China  
Tel: (86) 20-8221-4480 Ext. 261 Fax: (86) 20-8114-9279 & 20-8114-9283

Information herein is for reference only and subject to change without notice. It does not constitute any representation, warranty or commitment of the company in respect of the products in any aspect. All logos, brands and product names mentioned herein are trademarks or registered trademarks of their respective owners. The company does not assume any liability arising out of the application or use of any product or circuit described herein. Copyrights 2018, E & E Magnetic Products Limited.