

REVISIONS			
REV.	DESCRIPTION	ECN NO.	DATE
01	FIRST RELEASE FOR RFQ#A2020-15256	N/A	07/06/20

PAGE X IS FOR INTERNAL ONLY

PART NUMBER		PART DESCRIPTION		TITLE										
835-01500F		RoHS compliant per EU Directive (EU) 2015/863.		PXF, FLYBACK, RM7, 345uH, 30W, TH, 4PIN										
<p><b>WARNING !</b></p> <p>ALL SHEETS OF THIS DOCUMENT ARE CONTROLLED DOCUMENTATION AND ARE NOT TO BE RELEASED OUTSIDE OF E&amp;E OR ITS SUB-CONTRACTORS WITHOUT AUTHORIZATION.</p>	<p>UNLESS OTHERWISE SPECIFIED, DIMENSIONS ARE IN INCH/mm.</p> <p><u>TOLERANCE ARE:</u></p> <table border="0"> <tr> <td>INCH</td> <td>mm</td> <td>ANGLE</td> </tr> <tr> <td>.XXX ± .005</td> <td>.XX ± .13</td> <td>X.X ± 0.3</td> </tr> <tr> <td>.XX ± .02</td> <td>.X ± .5</td> <td>X. ± 1</td> </tr> </table>	INCH	mm	ANGLE	.XXX ± .005	.XX ± .13	X.X ± 0.3	.XX ± .02	.X ± .5	X. ± 1	APPROVALS	DATE	 E & E Magnetic Products Ltd.	
		INCH	mm	ANGLE										
		.XXX ± .005	.XX ± .13	X.X ± 0.3										
		.XX ± .02	.X ± .5	X. ± 1										
		DRAWN BY												
PROJ. ENG	Y.WANG	07/06/20		DRAWING NO./MODEL	REV									
APPROVED BY	K.DENG	07/06/20												
Q.A.	J.YANG	07/06/20				835-01500F	01							
	W.ZHANG	07/06/20		SCALE	PAGE			OF						
			DO NOT SCALE	1	4									

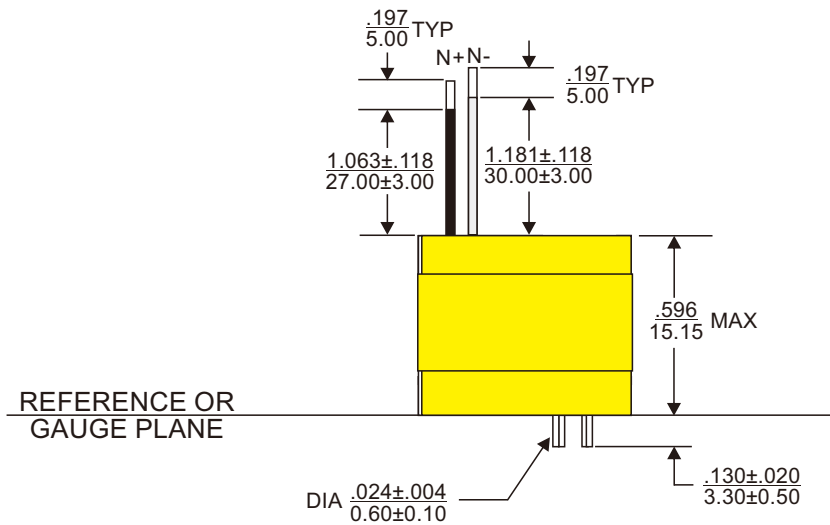
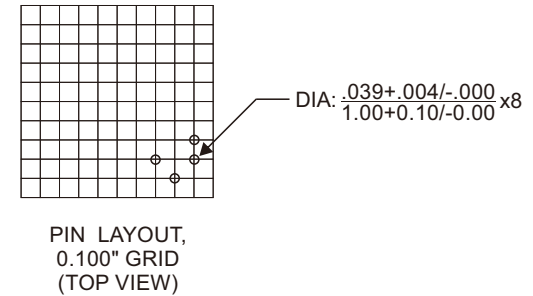
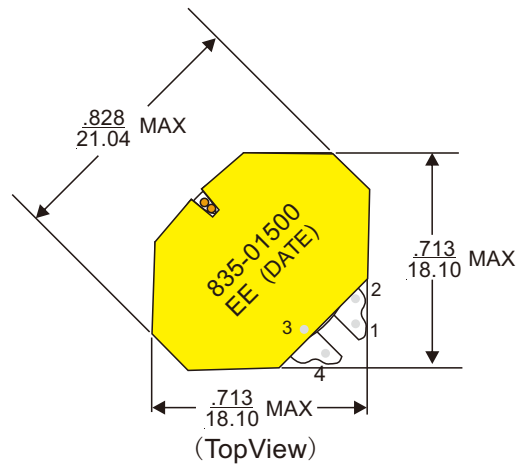

## MECHANICAL OUTLINE



E & E Magnetic Products Ltd.

DRAWING NO./MODEL

835-01500F

REV

01

SCALE

DO NOT SCALE

PAGE

2

OF

4

1. Dimension are specified in  $\frac{\text{inches}}{\text{mm}}$  with higher precedence in mm.
2. Unless otherwise specified, all tolerance are  $\pm \frac{.010}{0.25}$ .
3. "(DATE)" includes at least the manufacturing date code (in YYWW format) plus manufacturing site code.

### ELECTRICAL SPECIFICATION @25°C:

PARAMETERS	UNIT	LIMITS
Turns Ratio(3 - 4) : (N+ - N-) : (1 -2)	-	7 :1 :2 ± 2%
Polarity	-	Per Schematic
Ls(3-4)@100kHz, 1Vrms	uH	345TYP
LL(3-4), short other windings@100kHz, 1Vrms	uH	0.28 TYP
LL(3-4), short pin1,2@100kHz, 1Vrms	uH	0.55 TYP
DCR(3-4)	mΩ	428 TYP
DCR(N+ - N+)	mΩ	10.62 TYP
DCR(1-2)	mΩ	112 TYP
HIPOT(1,2,3,4):(N+ - N-), 5mA, 1min	Vrms	3000

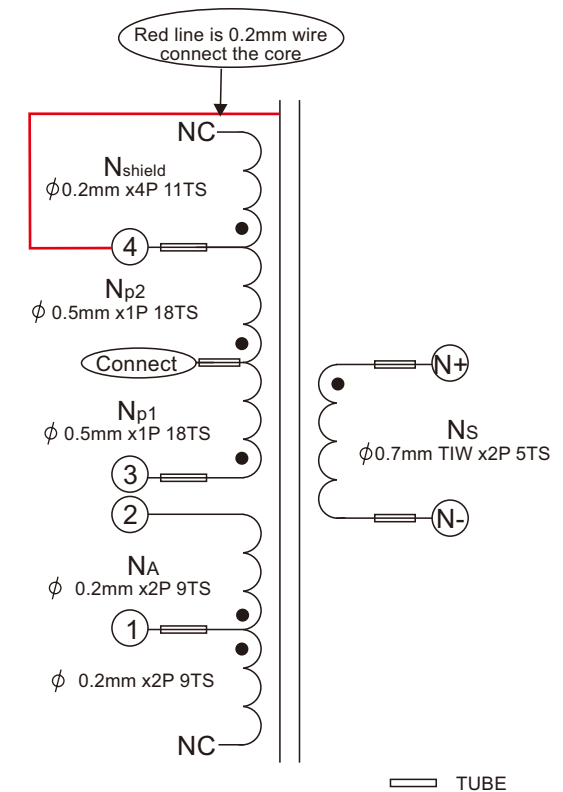

### SCHEMATIC

4. Operating temperature range: -40°C to +125°C. The part temperature (ambient temperature + temperature rise) should not exceed the upper limit of the operating temperature under worst case operating conditions. Circuit design, component placement, PWB trace size and thickness, airflow and other cooling provisions all affect the part temperature. Part temperature should be verified in the end application.



E & E Magnetic Products Ltd.

DRAWING NO./MODEL

835-01500F

REV

01

SCALE

DO NOT SCALE

PAGE

3

OF

4

## MATERIAL USAGE AND WINDING CONSTRUCTION

### (1) Materials.

No.	Item	Material name or Description	Thickness of one layer	Layer	UL file No.	Manufacture
1	Core	Ferrite	----	----	----	TDG/DMEGC/MAGSOURCE
2	Bobbin	T375J/T355J	0.79mm/0.62mm	----	E59481	CHANG CHUN PLASTICS CO LTD
		PM-9630/PM-9820	0.40mm/0.43mm	----	E41429	SUMITOMO BAKELITE CO LTD
		LCP4008/5008	0.30mm	----	E54705	SUMITOMO CHEMICAL CO LTD
3	Wire	Magnet wire (180°C)	----	----	E63382/E258243	ELEKTRISOLA INC
			----	----	E174837	JUNG SHING WIRE CO., LTD
			----	----	E32638	ESSEX
			----	----	E344738	ZHAO XIN YUAN ELECTRONICS TECHNOLOGY CO., LTD
4	Interleave Tape	Temperature class B (130°C or over)	----	----	E1950	3M
5	Out Wrapping Tape	Temperature class H (180°C or over)	----	----	E17385	3M
6	Varnish	BC359	----	----	E317427	John C Dolph
		T-4260(a)	----	----	E228349	SUZHOU TAIHU INSULATION MATERIAL
7	Tube	Teflon Tube (150°C)	----	----	E338209	DONGGUAN CITY CHANGJIE METALS & PLASTIC PRODUCTS CO.,LTD or equivalent
8	Insulated wire	Triple insulated wire (150°C)	----	----	E206198	Rubadue wire or equivalent

### (2) WINDING CONSTRUCTION

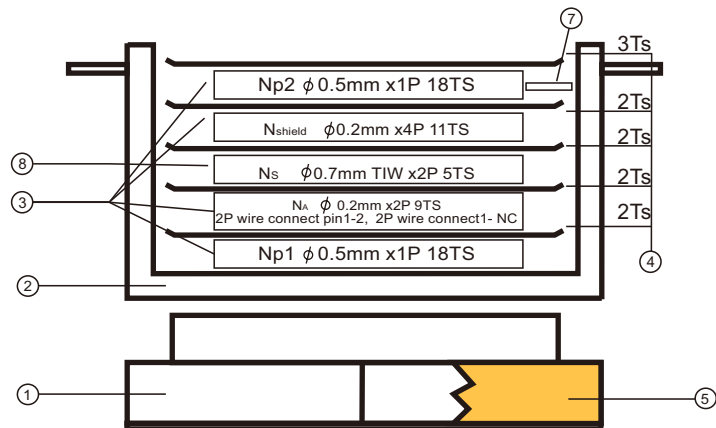

Safety Distances	
Primary to Second	N/A
Primary to Core	N/A
Second to Core	N/A



E & E Magnetic Products Ltd.

DRAWING NO./MODEL

835-01500F

REV

01

SCALE

DO NOT SCALE

PAGE

4

OF

4