

REVISIONS			
REV.	DESCRIPTION	ECN NO.	DATE
01	FIRST RELEASE	N/A	08/12/14

PAGE 5 & 6 ARE FOR INTERNAL ONLY

PART NUMBER	PART DESCRIPTION
824-00492F	RoHS compliant per EU Directive 2002/95/EC(without exemption of solder content)

TITLE	TRANSFORMER, 1000BASE-T(PoE Plus), QUAD, THRU-HOLE, 96 PIN
-------	---

WARNING !
 ALL SHEETS OF THIS DOCUMENT ARE CONTROLLED DOCUMENTATION AND ARE NOT TO BE RELEASED OUTSIDE OF E&E OR ITS SUB-CONTRACTORS WITHOUT AUTHORIZATION.

UNLESS OTHERWISE SPECIFIED, DIMENSIONS ARE IN INCH/mm.

TOLERANCE ARE:

INCH	mm	ANGLE
.XXX ± .005	.XX ± .13	X.X ± 0.3
.XX ± .02	.X ± .5	X. ± 1

APPROVALS	DATE
DRAWN BY B. XU	08/12/14
PROJ. ENG Y.L. YUNG	08/12/14
APPROVED BY D. YUNG	08/12/14
Q.A. D. LUO	08/12/14

 E & E Magnetic Products Ltd.	
DRAWING NO./MODEL	REV
824-00492F	01
SCALE DO NOT SCALE	PAGE 1 OF 6

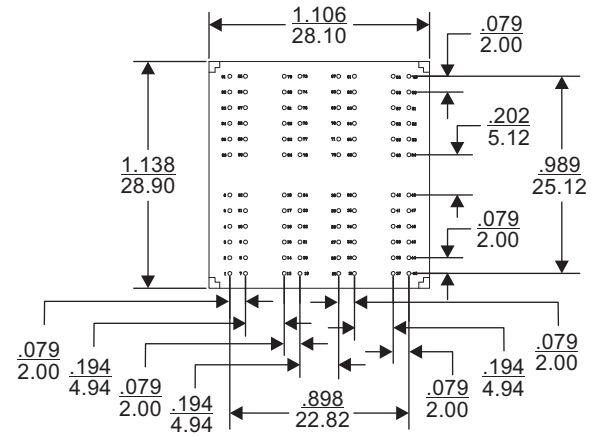
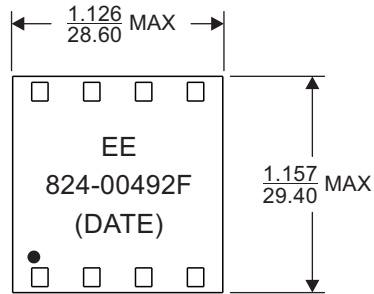

Recommended Pad Layout

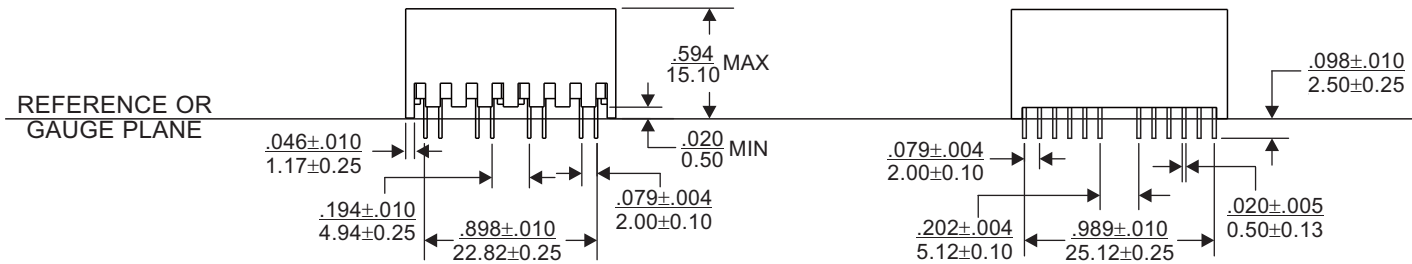

MECHANICAL OUTLINE



E & E Magnetic Products Ltd.

DRAWING NO./MODEL

824-00492F

REV

01

SCALE

DO NOT SCALE

PAGE

2

OF

6

- Dimensions are specified in $\frac{\text{inches}}{\text{mm}}$ with higher precedence in mm.
- "(DATE)" includes at least the manufacturing date code (in YYWW format) plus two character country code.

Line Side
(Secondary)

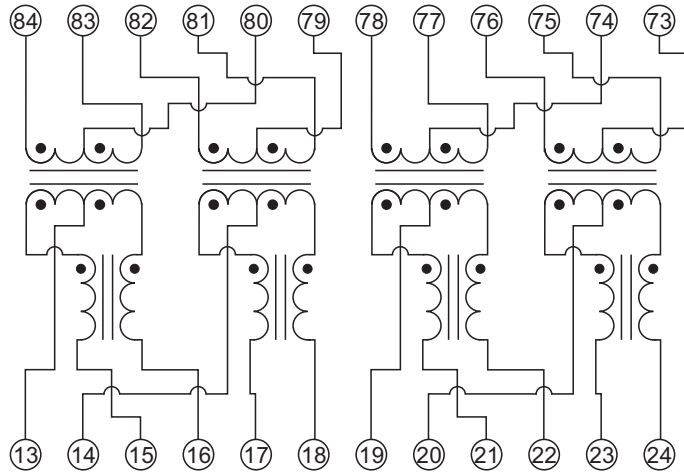

PHY Side
(Primary)

Line Side
(Secondary)

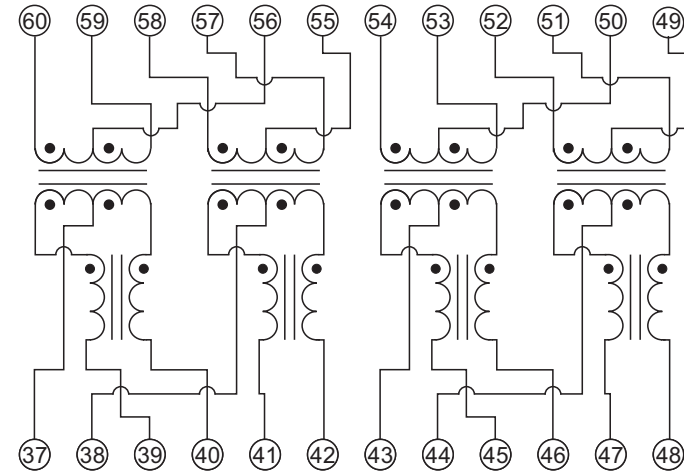

PHY Side
(Primary)

Line Side
(Secondary)

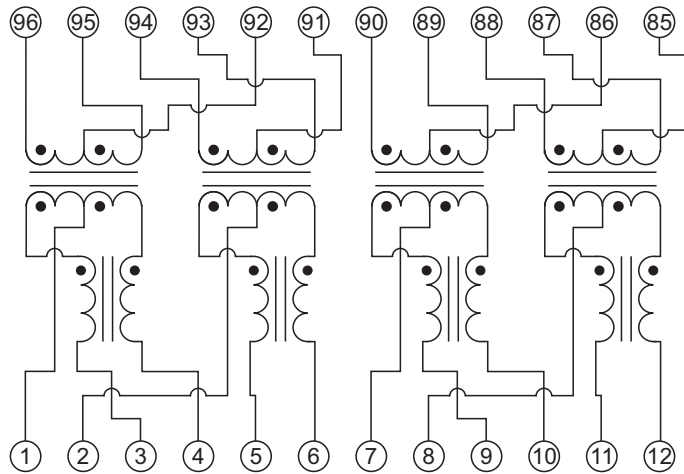

PHY Side
(Primary)

Line Side
(Secondary)

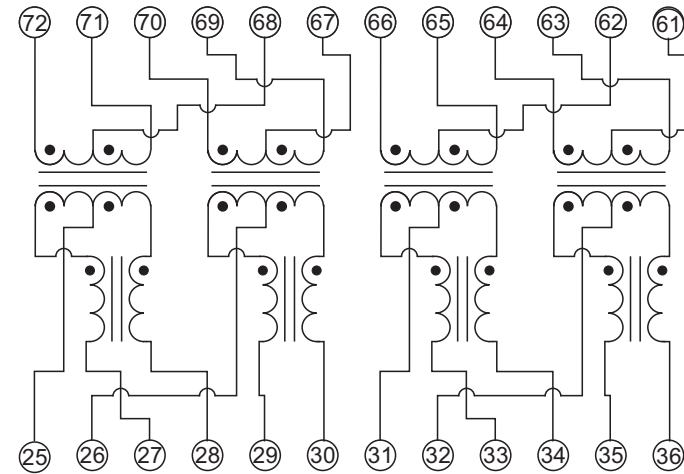

PHY Side
(Primary)

SCHEMATIC



E & E Magnetic Products Ltd.

DRAWING NO./MODEL

824-00492F

REV

01

SCALE

DO NOT SCALE

PAGE

3

OF

6

ELECTRICAL SPECIFICATION @25°C:

PARAMETERS	UNIT	EACH CHANNEL
Turns Ratio (Primary):(Secondary)	-	1CT:1CT ± 3%
Polarity (Primary):(Secondary)	-	Per Schematic
Inductance, Ls(Primary) @100kHz, 0.1Vrms, 11mADC	uH	350 Min
Inductance, Ls(Primary) @100kHz, 0.1Vrms, 18.3mADC	uH	120 Min
Insertion Loss @1-100MHz	dB	1.8 Max
Insertion Loss @100-125MHz	dB	3.0 Max
Return Loss @1-40MHz	dB	18.0 Min
Return Loss @60MHz	dB	14.5 Min
Return Loss @80MHz	dB	12.0 Min
Return Loss @100MHz	dB	10.0 Min
Crosstalk @30MHz, Between Channels	dB	43 Min
Crosstalk @60MHz, Between Channels	dB	37 Min
Crosstalk @100MHz, Between Channels	dB	30 Min
HIPOT (Primary):(Secondary)	Vrms	1500 Min

3. Operating temperature: 0°C to +70°C.

4. Balanced DC line current capability (Line Side):720mADC maximum.



E & E Magnetic Products Ltd.

DRAWING NO./MODEL

824-00492F

REV

01

SCALE

DO NOT SCALE

PAGE

4

OF

6